

SITRANS LR250 Hygienic Encapsulated Antenna

Overview



The SITRANS LR250 Hygienic Encapsulated Antenna is a 2-wire 25 GHz pulse radar level transmitter with sanitary and hygienic approvals for continuous monitoring of liquids, slurries, and pastes within the food, beverage, chemical, and pharmaceutical industries to a range of 20 m (66 ft) (antenna dependent).

Picture shown with accessories sold separately.

Benefits

- Fully encapsulated horn antenna design with FDA approved and USP Class VI compliant, TFM 1600 PTFE lens
- $0.8 \mu\text{Ra}$ surface finish for maximum cleanability and hygiene requirements commonly required in sanitary environments
- Chemically resistant TFM 1600 PTFE lens is also suitable for aggressive or corrosive materials
- Approved device in accordance with 3-A, EHEDG EL Class I and/or EHEDG EL Aseptic Class I
- Cost effective replacement for transmitters made of exotic materials
- Graphical local user interface (LUI) makes operation simple with plug-and-play set-up using the intuitive Quick Start Wizard
- Industry standard process connections including ISO 2852, DIN 11851, DIN 11864-1, DIN 11864-2, DIN 11864-3, and Tuchenhaugen Varivent Type F and N
- LUI displays echo profiles for diagnostic support
- 25 GHz high frequency and 2 inch (50 mm) process connection/antenna allow for easy mounting
- Insensitive to mounting location and obstructions, and less sensitive to nozzle interference
- Communication using HART or PROFIBUS PA
- Process Intelligence signal processing for improved measurement reliability and Auto False-Echo Suppression of fixed obstructions
- Programming using infrared Intrinsically Safe handheld programmer or over a network using SIMATIC PDM, Emerson AMS, or Field Device Tools, such as PACTware or Fieldcare via SITRANS DTM.
- Functional Safety (SIL 2). Device suitable for use in accordance with IEC 61508 and IEC 61511

Application

SITRANS LR250 includes a graphical local user interface (LUI) that improves set-up and operation by including an intuitive Quick Start Wizard, and echo profile displays for diagnostic support. Startup is easy using the Quick Start wizard with few parameters required for basic operation.

The 25 GHz frequency creates a narrow, focused beam allowing for smaller antenna options and decreasing sensitivity to obstructions. SITRANS LR250's unique design allows safe and simple programming using the Intrinsically Safe handheld programmer without having to open the instrument's lid.

SITRANS LR250 measures superbly in small vessels and in tanks/vessels up to 20 m (66 ft) on materials with $dk > 1.6$.

- Key Applications: applications within the food, beverage, chemical and pharmaceutical industries where sanitary, aseptic, or hygienic approvals are required or easy install/clean flush antennas are preferable, such as ice cream, fruit juice, milk, beer, and pharmaceutical or chemical additives and ingredients.

Configuration

Installation

Note:

- Beam angle is the width of the cone where the energy density is half of the peak energy density.
- The peak energy density is directly in front of and in line with the antenna.
- There is a signal transmitted outside of the beam angle; therefore false targets may be detected.

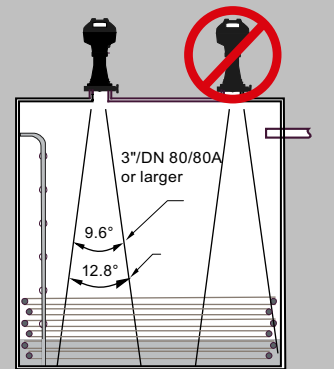

Mounting on vessel

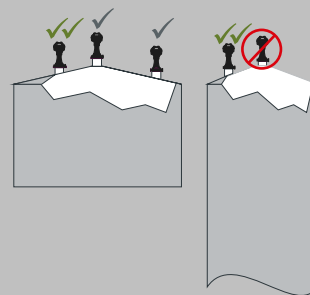

Mounting on a nozzle

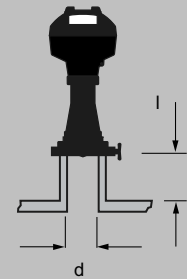

Nozzles should be maximum l/d ratio 1:1 (Eg. 50 mm length, 50 mm diameter)

LR250 Hygienic Encapsulated Antenna, dimensions in mm (inch)

SITRANS LR250 Hygienic Encapsulated Antenna

Selection and ordering data

		Article No.	
SITRANS LR250 Radar level transmitter with encapsulated horn and PTFE lens Continuous, non-contact, 20 m (66 ft) range, for liquids, solids, and slurries. For use in hygienic applications.		7ML5433- ● ● ● ● 0 - ● A ● ●	
Click on the Article No. for the online configuration in the PIA Life Cycle Portal.			
Hygienic/Sanitary Approvals			
EHEDG EL Class 1 ¹⁾		1	
EHEDG EL Aseptic Class 1 ¹⁾		2	
3-A (Tuchenhagen connections only - FC ... FF) ²⁾³⁾		3	
EHEDG EL Class I & 3-A (excludes Tuchenhagen connections) ²⁾⁴⁾		4	
Process Connection Types (all types have TFM1600 PTFE lens)			
<u>316L st/st [1.4435 or 1.4404]</u>			
2" Sanitary Clamp according to ISO 2852 ⁵⁾		A	A
3" Sanitary Clamp according to ISO 2852		A	B
4" Sanitary Clamp according to ISO 2852		A	C
<u>316L st/st (1.4435 or 1.4404) & 304L st/st (1.4301)</u>			
DN 50 Aseptic/Hygienic nozzle/ slotted nut (instrument side) to DIN 11864-1 [Form A] ⁵⁾		B	A
DN 80 Aseptic/Hygienic nozzle/ slotted nut (instrument side) to DIN 11864-1 [Form A]		B	B
DN 100 Aseptic/Hygienic nozzle/ slotted nut (instrument side) to DIN 11864-1 [Form A]		B	C
<u>316L st/st [1.4435 or 1.4404]</u>			
DN 50 Aseptic/Hygienic flanged to DIN 11864-2 [Form A] ⁵⁾		C	A
DN 80 Aseptic/Hygienic flanged to DIN 11864-2 [Form A]		C	B
DN 100 Aseptic/Hygienic flanged to DIN 11864-2 [Form A]		C	C
<u>316L st/st [1.4435 or 1.4404]</u>			
DN 50 Aseptic/Hygienic Clamp according to DIN 11864-3 [Form A] ⁵⁾		D	A
DN 80 Aseptic/Hygienic Clamp according to DIN 11864-3 [Form A]		D	B
DN 100 Aseptic/Hygienic Clamp according to DIN 11864-3 [Form A]		D	C
<u>316L st/st (1.4435 or 1.4404) & 304L st/st (1.4301)</u>			
DN 50 Hygienic nozzle/ slotted nut (instrument side) to DIN 11851 ⁵⁾		E	A
DN 80 Hygienic nozzle/ slotted nut (instrument side) to DIN 11851		E	B
DN 100 Hygienic nozzle/ slotted nut (instrument side) to DIN 11851		E	C
<u>316L st/st [1.4435 or 1.4404]</u>			
Type F (50 mm) Tuchenhagen Varivent (EHEDG only) ⁵⁾		F	A
Type N (68 mm) Tuchenhagen Varivent (EHEDG only) ⁵⁾		F	B
Type F (50 mm) Tuchenhagen Varivent [3-A only & EPDM process seal -40 ... 120 °C (-40 ... 248 °F)] ⁵⁾		F	C
Type N (68 mm) Tuchenhagen Varivent [3-A only & EPDM process seal -40 ... 120 °C (-40 ... 248 °F)] ⁵⁾		F	D
Type F (50 mm) Tuchenhagen Varivent [3-A only & FKM process seal -20 ... 170 °C (-4 ... 338 °F)] ⁵⁾		F	E
Type N (68 mm) Tuchenhagen Varivent [3-A only & FKM process seal -20 ... 170 °C (-4 ... 338 °F)] ⁵⁾		F	F
Communication			
PROFIBUS PA			1
4 ... 20 mA HART, start-up at < 3.6 mA			2
Enclosure			
Aluminum, Epoxy paint, 2 X ½" NPT			0
Aluminum, Epoxy paint, 2 X M20 x 1.5			1
Approvals			
Ordinary Locations/General Purpose (Non-Ex), CE, UKCA, CSA, FM, FCC, RED, RCM			A
Intrinsically Safe: CSA/FM Class I, Div. 1, Groups A, B, C, D, Class II, Div. 1, Groups E, F, G, Class III T4 FCC, Industry Canada			B

Selection and ordering data (continued)

SITRANS LR250 Radar level transmitter with encapsulated horn and PTFE lens Continuous, non-contact, 20 m (66 ft) range, for liquids, solids, and slurries. For use in hygienic applications.	Article No. 7ML5433- ● ● ● ● 0 - ● A ● ●
Intrinsically Safe: ATEX II 1G Ex ia IIC T4 Ga, ATEX II 1D Ex ia ta IIIC T100°C Da; UKEX II 1G Ex ia IIC T4 Ga, UKEX II 1D Ex ia ta IIIC T100°C Da; IECEX Ex ia IIC T4 Ga, IECEX 1D Ex ia ta IIIC T100°C Da; INMETRO Ex ia IIC T4 Ga, INMETRO Ex ia ta IIIC T100°C Da, IP67/IP68; EAC Ex 0Ex ia IIC T4 Ga X, EAC Ex 0Ex ia ta IIIC T100°C Da X; CE, UKCA, RED, RCM	C
Non-incendive: CSA/FM Class I, Div. 2, Groups A, B, C, D T5, FCC, Industry Canada	D
Increased Safety / Non Sparking: ATEX II 3G Ex ec IIC T4 Gc; UKEX II 3G Ex ec IIC T4 Gc; EAC Ex 2Ex nA IIC T4 Gc X; CE, UKCA, RED, RCM	E
Increased Safety: ATEX II 1/2 GD, 1D, 2D, Ex eb mb ia IIC T4 Ga/Gb; UKEX II 1/2 GD, 1D, 2D, Ex eb mb ia IIC T4 Ga/Gb; IECEX Ex eb ia mb IIC T4 Ga/Gb; INMETRO Ex e ia mb IIC T4 Ga/Gb, INMETRO Ex ia ta IIIC T100°C Da, IP67/IP68; EAC Ex Ga/Gb Ex ia/e+mb IIC T4 X; CE, UKCA, RED, RCM ⁶⁾	F
Flameproof: ATEX II 1/2 GD, 1D, 2D, Ex db mb ia IIC T4 Ga/Gb; ATEX II 1/2 GD, 1D, 2D, Ex ia ta IIIC T100°C Da; UKEX II 1/2 GD, 1D, 2D, Ex db mb ia IIC T4 Ga/Gb; UKEX II 1/2 GD, 1D, 2D, Ex ia ta IIIC T100°C Da; IECEX Ex db mb ia IIC T4 Ga/Gb, IECEX Ex ia ta IIIC T100°C Da; INMETRO Ex d ia mb IIC T4 Ga/Gb, INMETRO Ex ia ta IIIC T100°C Da, IP67/IP68; EAC Ex Ga/Gb Ex ia/db+mb IIC T4 X, EAC Ex Ex ia ta IIIC T100°C Da; CE, UKCA, RED, RCM ⁶⁾	G
Explosion proof: CSA/FM Class I, II and III, Div. 1, Groups A, B, C, D, E, F, G, FCC, Industry Canada ⁶⁾	H
Non Sparking: NEPSI Ex nA IIC T4 Gc	K
Intrinsically Safe: NEPSI Ex ia IIC T4 Ga, Ex iaD tD A20 IP67 T100 °C	L
Flameproof: NEPSI Ex d ia mb IIC T4 Ga/Gb, Ex iaD tD A20 IP67 T100 °C ⁶⁾	M
Increased Safety: NEPSI Ex e ia mb IIC T4 Ga/Gb, Ex iaD tD A20 IP67 T100 °C ⁶⁾	N
Pressure Rating Rating per pressure/temperature curves in instruction manual	0

Selection and Ordering data	Order code
Further designs Please add "-Z" to Article No. and specify Order code(s). Electrical Connection cable entry:	
Plug M12 (IP 67 rating) with mating connector ²⁾⁷⁾⁸⁾	A50
Plug 7/8" (IP 67 rating) with mating connector ²⁾⁸⁾⁹⁾	A55
Test Certificates	
Manufacturer's Test Certificate M to DIN 55350, Part 18 and to ISO 9000	C11
Material inspection Certificate 3.1 of EN 10204	C12
Functional Safety	



Selection and Ordering data	Order code
Functional Safety (SIL 2). Device suitable for use in accordance with IEC 61508 and IEC 61511 ⁶⁾¹⁰⁾ Namur	C20
Namur NE43 compliant, device preset to failsafe < 3.6 mA ⁶⁾ Tagging	N07
Stainless steel tag [69 mm x 50 mm (2.71 x 1.97 inch)] Measuring-point number / identification (max. 27 characters) specify in plain text	Y15

SITRANS LR250 Hygienic Encapsulated Antenna

Selection and ordering data (continued)

Accessories	Article No.
Operating Instructions	
All literature is available to download for free, in a range of languages, at http://www.siemens.com/processinstrumentation/documentation	
Accessories	
Handheld programmer, Intrinsically safe, EEx ia (LUI enabled)	7ML1930-1BK
HART modem with USB interface	7MF4997-1DC
One metallic cable gland M20 x 1.5, rated -40 ... +80 °C (-40 ... +176 °F), HART (two are required) ⁶⁾	7ML1930-1AP
One metallic cable gland M20 x 1.5, rated -40 ... +80 °C (-40 ... +176 °F), PROFIBUS PA (two are required) ⁸⁾	7ML1930-1AQ
SITRANS RD100, loop powered display - see Chapter 7	7ML5741-.....
SITRANS RD150, remote digital display for 4 ... 20 mA and HART devices - see Chapter 7	7ML5742-.....
SITRANS RD200, universal input display with Modbus conversion - see Chapter 7	7ML5740-.....
SITRANS RD300, dual line display with totalizer and linearization curve and Modbus conversion - see Chapter 7	7ML5744-.....
For applicable back up point level switch - see point level measurement section	

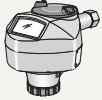
- 1) Available with Process connection options AA ... FB & FF only.
- 2) Available with Approval options A, B, C, L only.
- 3) Available with Process connections FC ... FF only.
- 4) Available with Process connection options AA ... EC & FF only.
- 5) Max. range 10 m (32.8 ft), dk > 3 [20 m (66 ft) and dk > 1.6 if installed in a stillpipe].
- 6) Applicable with Communication option 2 only.
- 7) Available with Enclosure option 1 only.
- 8) Available with Communication options 1 and 3 only.
- 9) Available with Enclosure option 0 only.
- 10) Available with Approval options A, B, C, D, E, K, L only.

SITRANS LR250 hygienic encapsulated Specials	Order code
For "Electronics Head only" follow the standard configuration and choose YY option on positions 9 and 10 of the full part number. For example: 7ML5433-1YY20-1AA0 will order an electronics head for the following: EHEDG EL Class 1 approval, 4 ... 20 mA HART, M20 cable entries, General purpose Haz Loc approval, pressure rating as per manual.	
Spare Lens Kits (Lens and O-ring)	
Kit, 2 inch, ISO 2852, HEA, Lens, silicone secondary O-ring	A5E32572731
Kit, 3 inch, ISO 2852, HEA, Lens, silicone secondary O-ring	A5E32572745
Kit, 4 inch, ISO 2852, HEA, Lens, silicone secondary O-ring	A5E32572747
Kit, DN 50, DIN 11851, HEA, Lens, silicone secondary O-ring	A5E32572758
Kit, DN 80, DIN 11851, HEA, Lens, silicone secondary O-ring	A5E32572770
Kit, DN 100, DIN 11851, HEA, Lens, silicone secondary O-ring	A5E32572772
Kit, DN 50, DIN 11864-1, HEA, Lens, silicone secondary O-ring	A5E32572773
Kit, DN 80, DIN 11864-1, HEA, Lens, silicone secondary O-ring	A5E32572779
Kit, DN 100, DIN 11864-1, HEA, Lens, silicone secondary O-ring	A5E32572782

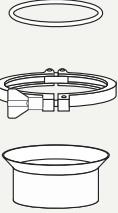
SITRANS LR250 hygienic encapsulated Specials	Order code
Kit, DN 50, DIN 11864-2/3, HEA, Lens, silicone secondary O-ring	A5E32572785
Kit, DN 80, DIN 11864-2/3, HEA, Lens, silicone secondary O-ring	A5E32572790
Kit, DN 100, DIN 11864-2/3, HEA, Lens, silicone secondary O-ring	A5E32572791
Kit, Tuchenhausen, Type F, HEA, Lens, silicone secondary O-ring	A5E32572794
Kit, Tuchenhausen, Type N, HEA, Lens, silicone secondary O-ring	A5E32572795
Accessories (customer side process connection and FKM and EPDM seal for each size and type)	
	
Kit DN50 DIN11864-1 GS Form A tank connection, EPDM Seal Class II	A5E32910638
Kit DN50 DIN11864-2 Form A tank connection, M8 Hardware (nut/bolt/washer), FKM Seal Class I	A5E32910805
Kit DN80 DIN11864-2 Form A tank connection, M10 Hardware (nut/bolt/washer), FKM Seal Class I	A5E32910809
Kit DN100 DIN11864-2 Form A tank connection, M10 Hardware (nut/bolt/washer), FKM Seal Class I	A5E32910812
Kit DN50 DIN11864-3 Form A tank connection, Clamp, EPDM Seal Class II	A5E32910813
Kit DN80 DIN11864-3 Form A tank connection, Clamp, EPDM Seal Class II	A5E32910814
Kit DN100 DIN11864-3 Form A tank connection, Clamp, EPDM Seal Class II	A5E32910815
Kit DN50 DIN11864-3 Form A tank connection, Clamp, FKM Seal Class I	A5E32910816
Kit DN80 DIN11864-3 Form A tank connection, Clamp, FKM Seal Class I	A5E32910817
Kit DN100 DIN11864-3 Form A tank connection, Clamp, FKM Seal Class I	A5E32910818
Kit Type F, Tuchenhausen, Clamp, EPDM Seal Class II (EHEDG only) - no tank connection	A5E33489537
Kit Type N, Tuchenhausen, Clamp, EPDM Seal Class II (EHEDG only) - no tank connection	A5E33489543
Kit Type F, Tuchenhausen, Clamp, FKM Seal Class I (EHEDG only) - no tank connection	A5E33489828
Kit Type N, Tuchenhausen, Clamp, FKM Seal Class I (EHEDG only) - no tank connection	A5E33489830
Ex-proof plugs	
Ex-proof plugs kit, 1/2" NPT, qty 5	A5E39979991
Ex-proof plugs kit, M20, qty 5	A5E39979992

¹¹⁾ Class II for low fat applications when EPDM seal used on DIN 11851

SITRANS LR250 Hygienic Encapsulated Antenna

Technical specifications

SITRANS LR250 Hygienic Encapsulated Antenna	
Mode of Operation	
Measuring principle	Radar level measurement
Frequency	K-band (25.0 GHz)
Minimum measuring range	50 mm (2 inch) from end of antenna
Maximum measuring range	20 m (66 ft)
Output	
HART	Version 5.1
• Analog output	4 ... 20 mA
• Accuracy	± 0.02 mA
• Fail-safe	<ul style="list-style-type: none"> • Programmable as high low or hold (loss of echo) • NE 43 programmable
PROFIBUS PA	Profile 3.01
• Function blocks	2 Analog Input (AI)
Performance (according to reference conditions IEC60770-1)	
Maximum measured error	<ul style="list-style-type: none"> • > 500 mm from sensor reference point: 3 mm (0.118 inch) • < 500 mm from sensor reference point: 25 mm (1 inch)
Influence of ambient temperature	< 0.003 %/K
Rated operating conditions	
Installation conditions	
• Location	Indoor/outdoor
Ambient conditions (enclosure)	
• Ambient temperature	-40 ... +80 °C (-40 ... +176 °F)
• Storage temperature	-40 ... +80 °C (-40 ... +176 °F)
• Installation category	I
• Pollution degree	4
Medium conditions	
Dielectric constant ϵ_r	≥ 1.6 (antenna dependent)
Process temperature	-40 ... +170 °C (-40 ... +338 °F) at process connection
Process pressure	See Pressure/Temperature curves for more information
Design	
Enclosure	
• Material	Aluminum, polyester powder coated
• Cable inlet	2 x M20 x 1.5 or 2 x 1/2" NPT
Degree of protection	Type 4X/NEMA 4X, Type 6/NEMA 6, IP67, IP68
Weight (dependent on process connection)	<ul style="list-style-type: none"> • Approx. 4.7 kg (10.4 lb) for 2" ISO 2852 (smallest size) • Approx. 7.9 kg (17.4 lb) for DN 100 DIN 11864-2 (largest size)
Display (local)	Graphic local user interface including quick start wizard and echo profile display
Antenna	
• Material	Stainless steel 316L (1.4435 or 1.4404) and TFM 1600 PTFE Lens (lens is the only wetted part)
• Lens surface finish (Ra)	0.8 µm

Technical specifications (continued)

SITRANS LR250 Hygienic Encapsulated Antenna	
Process connections	
Hygienic/Sanitary connections	<ul style="list-style-type: none"> • 2", 3" & 4" Sanitary Clamp according to ISO 2852 • DN 50, DN 80 & DN 100 Aseptic/Hygienic threaded to DIN 11864-1 [Form A] • DN 50, DN 80 & DN 100 Aseptic/Hygienic flanged to DIN 11864-2 [Form A] • DN 50, DN 80 & DN 100 Aseptic/Hygienic Clamp according to DIN 11864-3 [Form A] • DN 50, DN 80 & DN 100 Hygienic Union according to DIN 11851 • Type F (50 mm) & Type N (68 mm) Tuchenhausen Varivent
Power supply	
4 ... 20 mA/HART	Nominal 24 V DC (max. 30 V DC) with max. 550 Ω
PROFIBUS PA	<ul style="list-style-type: none"> • 15 mA • Per IEC 61158-2
Certificates and approvals	
General	cCSAus, CE, UKCA, FM, RCM
Radio	FCC, Industry Canada, RED, RCM
Hazardous	
• Explosion Proof (Brazil)	INMETRO Ex d ia mb IIC T4 Ga/Gb, Ex ia ta IIIC T100 °C Da
• Increased Safety (Brazil)	INMETRO Ex e ia mb IIC T4 Ga/Gb, Ex ia ta IIIC T100 °C Da
• Intrinsically Safe (Brazil)	INMETRO Ex ia IIC T4 Ga, Ex ia ta IIIC T100 °C Da
• Explosion Proof (Canada/USA)	CSA/FM Class I, Div. 1, Groups A, B, C, D; Class II, Div. 1, Groups E, F, G; Class III T4
• Intrinsically Safe (Canada/USA)	CSA/FM Class I, Div. 1, Groups A, B, C, D; Class II, Div. 1, Groups E, F, G; Class III T4
• Non-incendive (Canada/USA)	CSA/FM Class I, Div. 2, Groups A, B, C, D T5
• Flame Proof/Increased Safety (China)	NEPSI Ex d ia mb IIC T4 Ga/Gb, Ex e ia mb IIC T4 Ga/Gb, Ex iaD tD A20 IP67 T100 °C
• Intrinsically Safe (China)	NEPSI Ex ia IIC T4 Ga, Ex iaD tD A20 IP67 T100 °C
• Non-sparking (China)	NEPSI Ex nA IIC T4 Gc
• Intrinsically Safe (EU)	ATEX II 1G Ex ia IIC T4 Ga, ATEX II 1D Ex ia ta IIIC T100°C Da;
• Intrinsically Safe (UK)	UKEX II 1G Ex ia IIC T4 Ga, UKEX II 1D Ex ia ta IIIC T100°C Da;
• Intrinsically Safe (International)	IECEx Ex ia IIC T4 Ga, IECEx Ex ia ta IIIC T100°C Da;
• Increased Safety - Zone 2 (EU)	ATEX II 3G Ex ec IIC T4 Gc;
• Increased Safety - Zone 2 (UK)	UKEX II 3G Ex ec IIC T4 Gc;
• Non-sparking (EAC)	EAC Ex 2Ex nA IIC T4 Gc;
• Flameproof (EU)	ATEX II 1/2 GD, 1D, 2D, Ex db mb ia IIC Ga/Gb, Ex ia ta IIIC T100°C Da;
• Flameproof (UK)	UKEX II 1/2 GD, 1D, 2D, Ex db mb ia IIC Ga/Gb, Ex ia ta IIIC T100°C Da;
• Flameproof (International)	IECEx Ex db mb ia IIC T4 Ga/Gb, Ex ia ta IIIC T100°C Da;
• Increased Safety - Zone 1 (EU)	ATEX II 1/2 GD, 1D, 2D, Ex eb mb ia IIC T4 Ga/Gb, Ex ia ta IIIC T100°C Da;
• Increased Safety - Zone 1 (UK)	UKEX II 1/2 GD, 1D, 2D, Ex eb mb ia IIC T4 Ga/Gb, Ex ia ta IIIC T100°C Da;
• Increased Safety - Zone 1 (International)	IECEx Ex eb mb ia IIC T4 Ga/Gb, Ex ia ta IIIC T100°C Da
• Explosion Proof (Russia/Kazakhstan)	EAC Ex d
• Increased Safety (Russia/Kazakhstan)	EAC Ex e

SITRANS LR250 Hygienic Encapsulated Antenna

Technical specifications (continued)

SITRANS LR250 Hygienic Encapsulated Antenna	
<ul style="list-style-type: none"> Intrinsically Safe (Russia/Kazakhstan) 	EAC Ex ia
Hygienic/Sanitary	EHEDG EL Class I EHEDG EL Aseptic Class I
Programming Intrinsically Safe Siemens handheld programmer <ul style="list-style-type: none"> Approvals for handheld programmer 	Infrared receiver IS model: ATEX II 1 GD Ex ia op is IIC T4 Ga ATEX II 1 GD Ex ia op is IIIC T135°C Da UKEX II 1 GD Ex ia op is IIC T4 Ga UKEX II 1 GD Ex ia op is IIIC T135°C Da Ta = -20 ... +50°C CSA/FM Class I, II, III, Div. 1, Groups A, B, C, D, E, G, T6 Ta = 50°C IECEx SIR 09.0073
Handheld communicator	HART communicator 375/475
PC	<ul style="list-style-type: none"> SIMATIC PDM Emerson AMS SITRANS DTM (for connection into FDT, such as PACTware or Fieldcare)
Display (local)	Graphic local user interface including quick start wizard and echo profile displays

Characteristic curves

DIN 11851 Sanitary/Hygienic nozzle/slotted nut: DN 50, DN 80, and DN 100
 DIN 11864-1 Aseptic/Hygienic nozzle/slotted nut: DN 50, DN 80, and DN 100

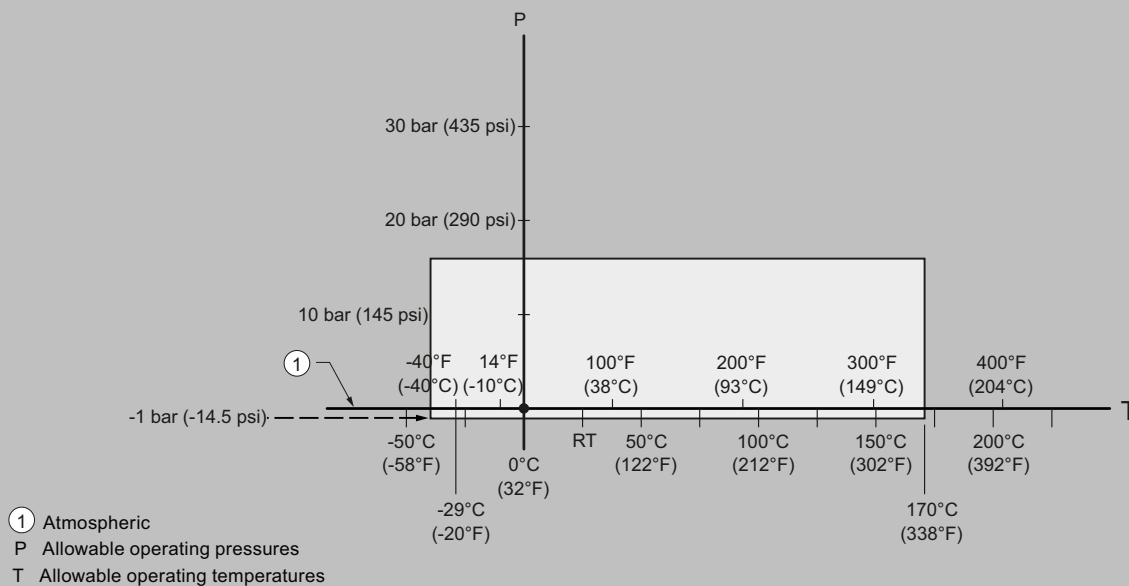

SITRANS LR250 Hygienic Encapsulated Antenna, process pressure/temperature rating curve

DIN 11864-2 Aseptic/Hygienic flanged: DN 50, DN 80, and DN 100

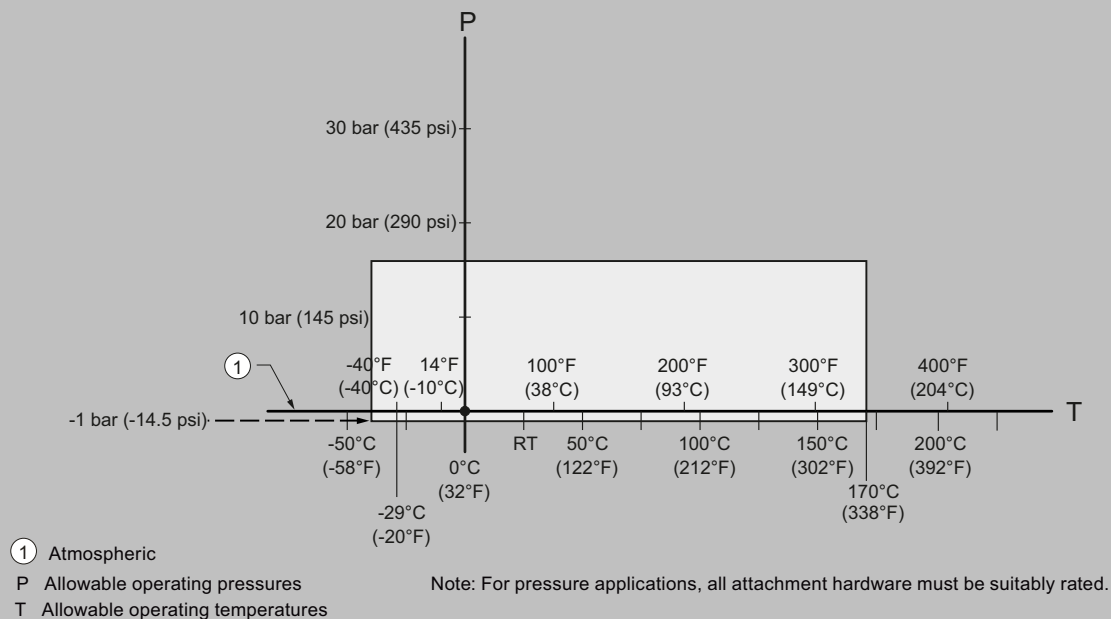

SITRANS LR250 Hygienic Encapsulated Antenna, process pressure/temperature rating curve

SITRANS LR250 Hygienic Encapsulated Antenna

Characteristic curves (continued)

DIN 11864-3 Aseptic/Hygienic clamp: DN 50, DN 80, and DN 100
 ISO 2852 Sanitary/Hygienic clamp: 2", 3", and 4"
 Tuchenhausen Varivent face seal clamp: Type N (68 mm) and Type F (50 mm)

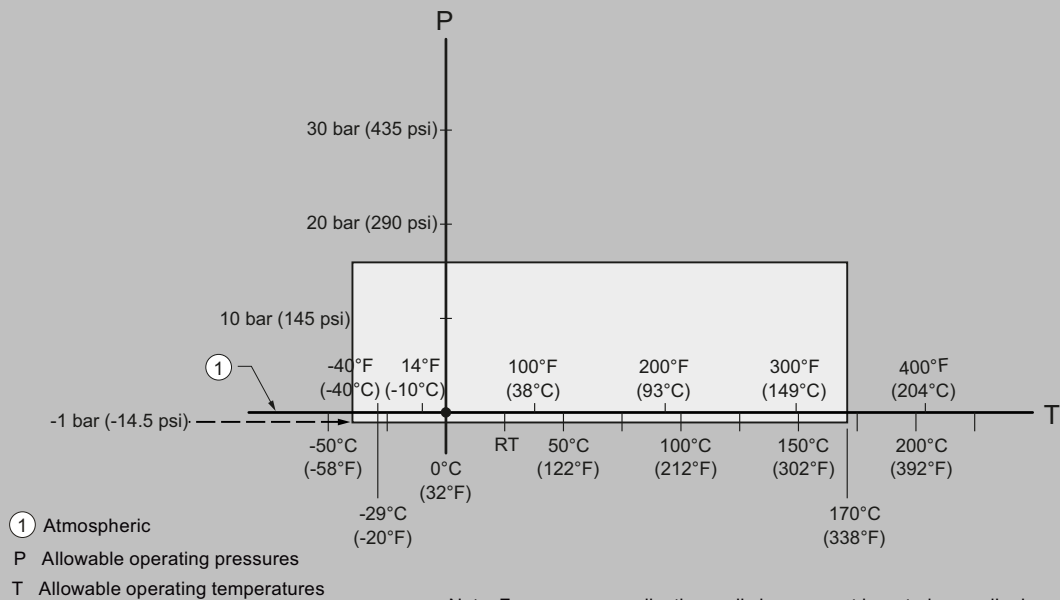

SITRANS LR250 Hygienic Encapsulated Antenna, process pressure/temperature rating curve

Dimensional drawings

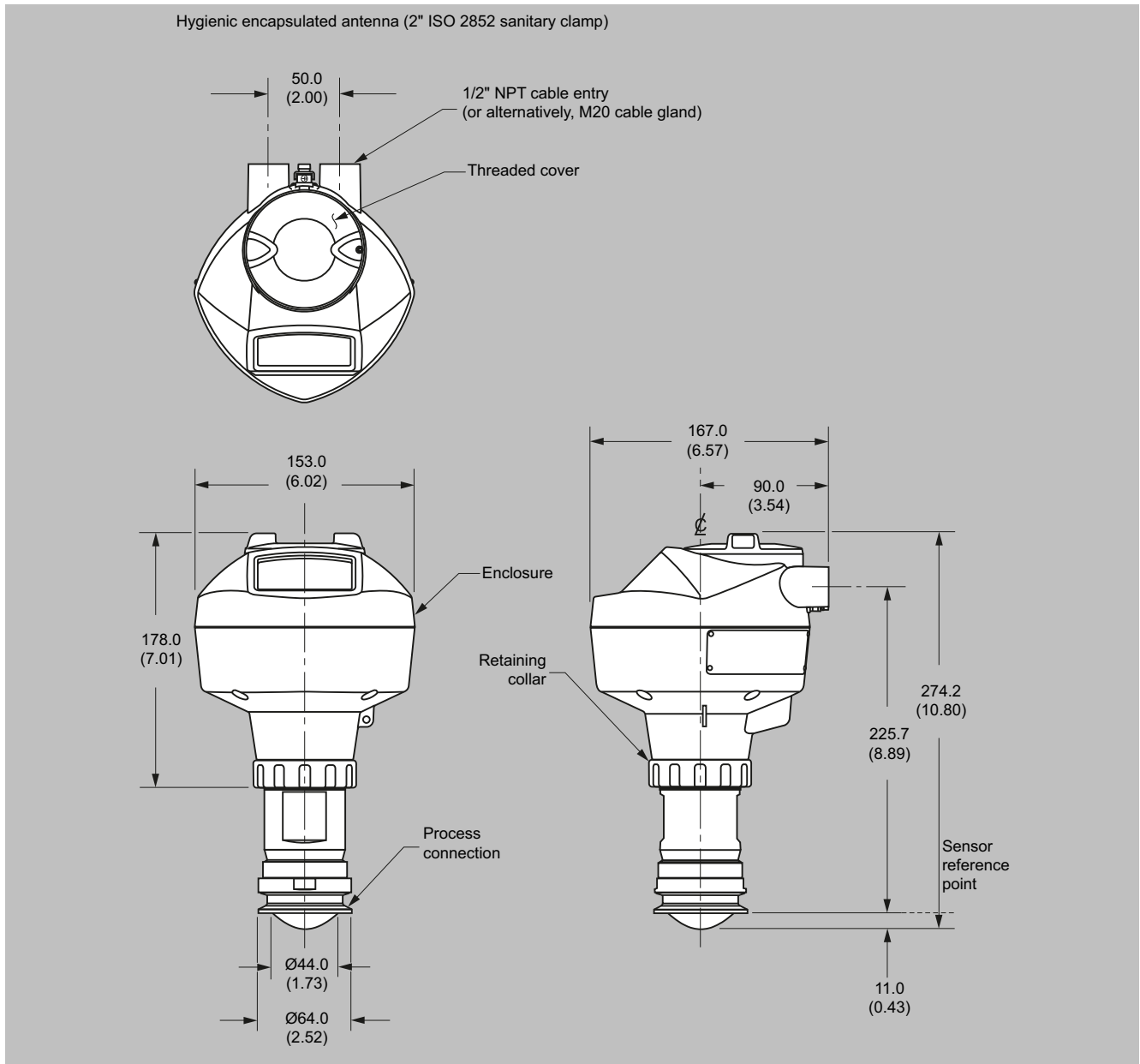

SITRANS LR250 Hygienic Encapsulated Antenna (2" ISO 2852 sanitary clamp), dimensions in mm (inch)

SITRANS LR250 Hygienic Encapsulated Antenna

Dimensional drawings (continued)

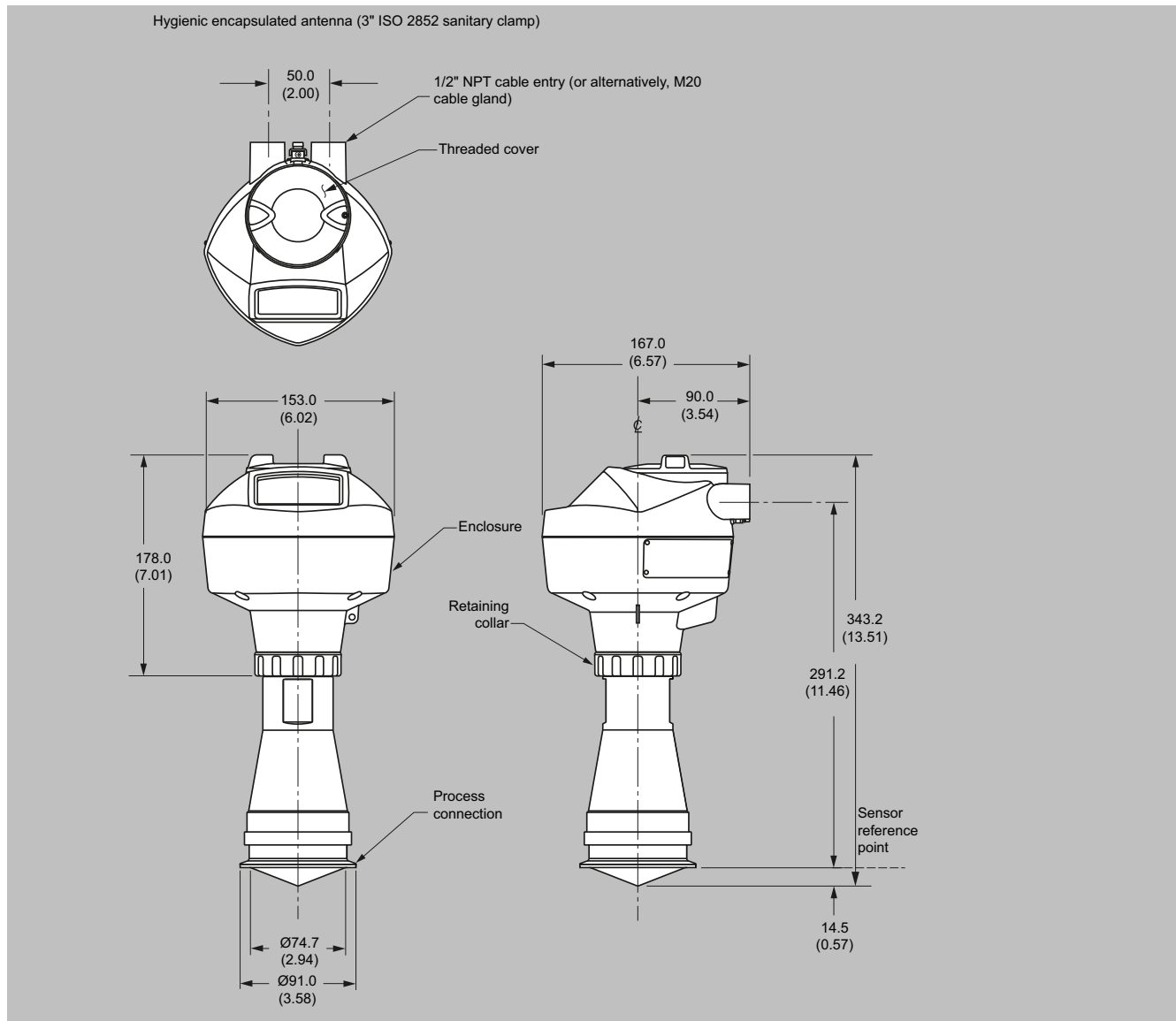

SITRANS LR250 Hygienic Encapsulated Antenna (3" ISO 2852 sanitary clamp), dimensions in mm (inch)

Dimensional drawings (continued)

Hygienic encapsulated antenna (4" ISO 2852 sanitary clamp)

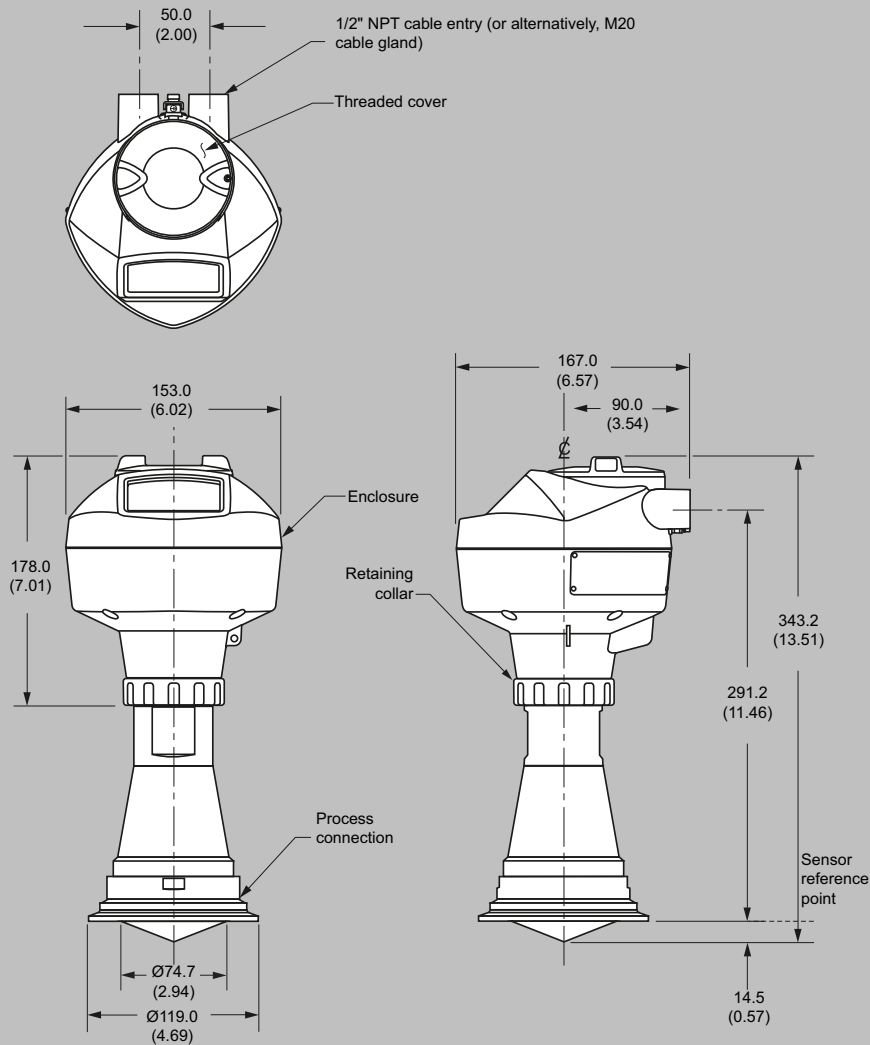

SITRANS LR250 Hygienic Encapsulated Antenna (4" ISO 2852 sanitary clamp), dimensions in mm (inch)

SITRANS LR250 Hygienic Encapsulated Antenna

Dimensional drawings (continued)

Hygienic encapsulated antenna (DN 50 nozzle/slotted nut to DIN 11851)

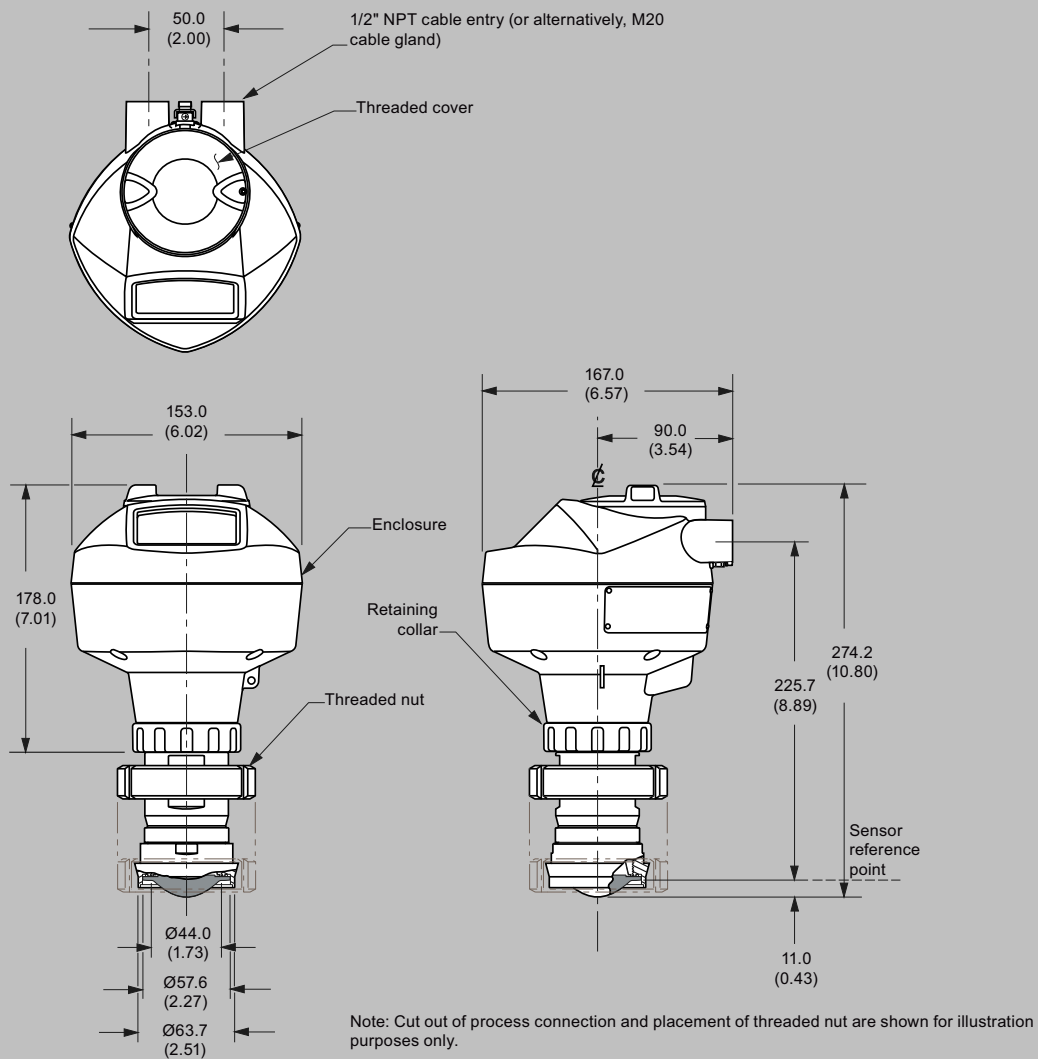

SITRANS LR250 Hygienic Encapsulated Antenna (DN 50 nozzle/slotted nut to DIN 11851), dimensions in mm (inch)

Dimensional drawings (continued)

Hygienic encapsulated antenna (DN 80 nozzle/slotted nut to DIN 11851)

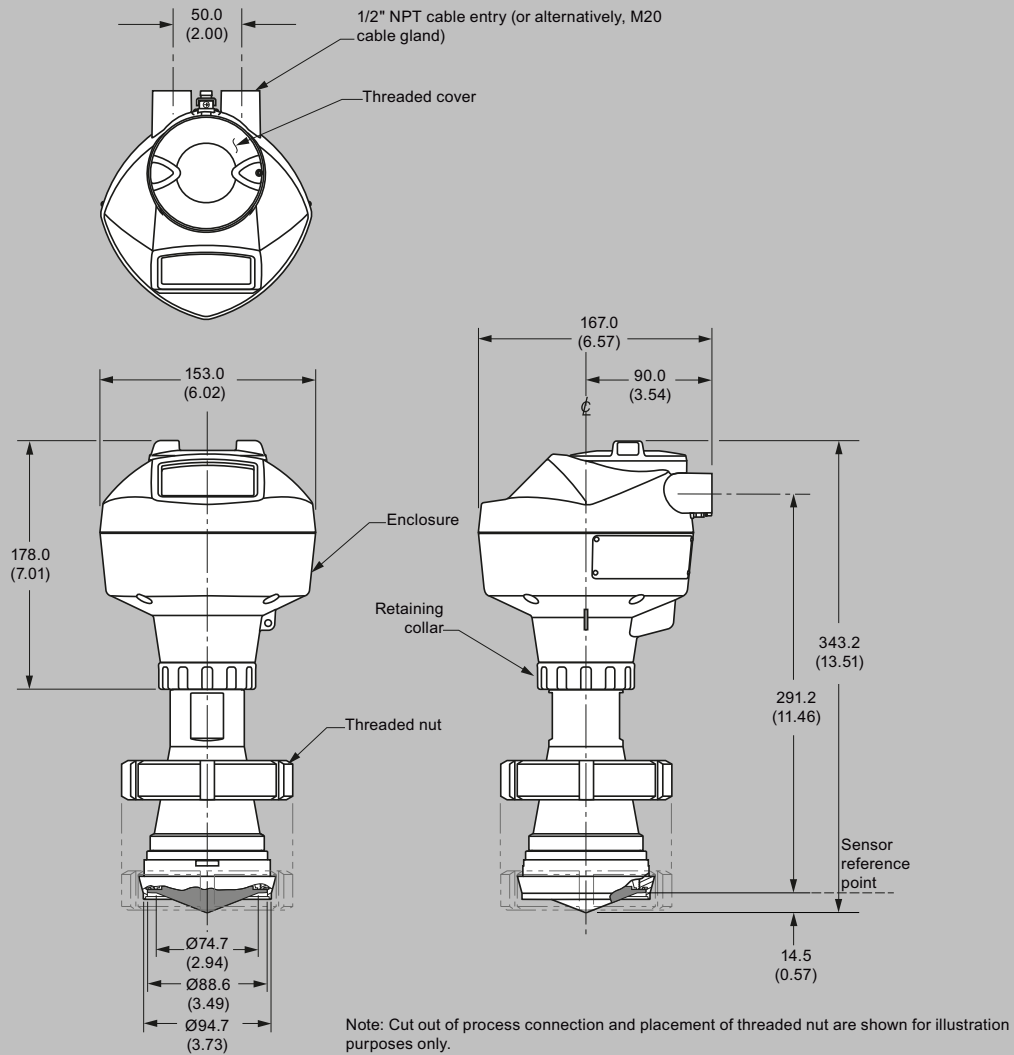

SITRANS LR250 Hygienic Encapsulated Antenna (DN 80 nozzle/slotted nut to DIN 11851), dimensions in mm (inch)

SITRANS LR250 Hygienic Encapsulated Antenna

Dimensional drawings (continued)

Hygienic encapsulated antenna (DN 100 nozzle/slotted nut to DIN 11851)

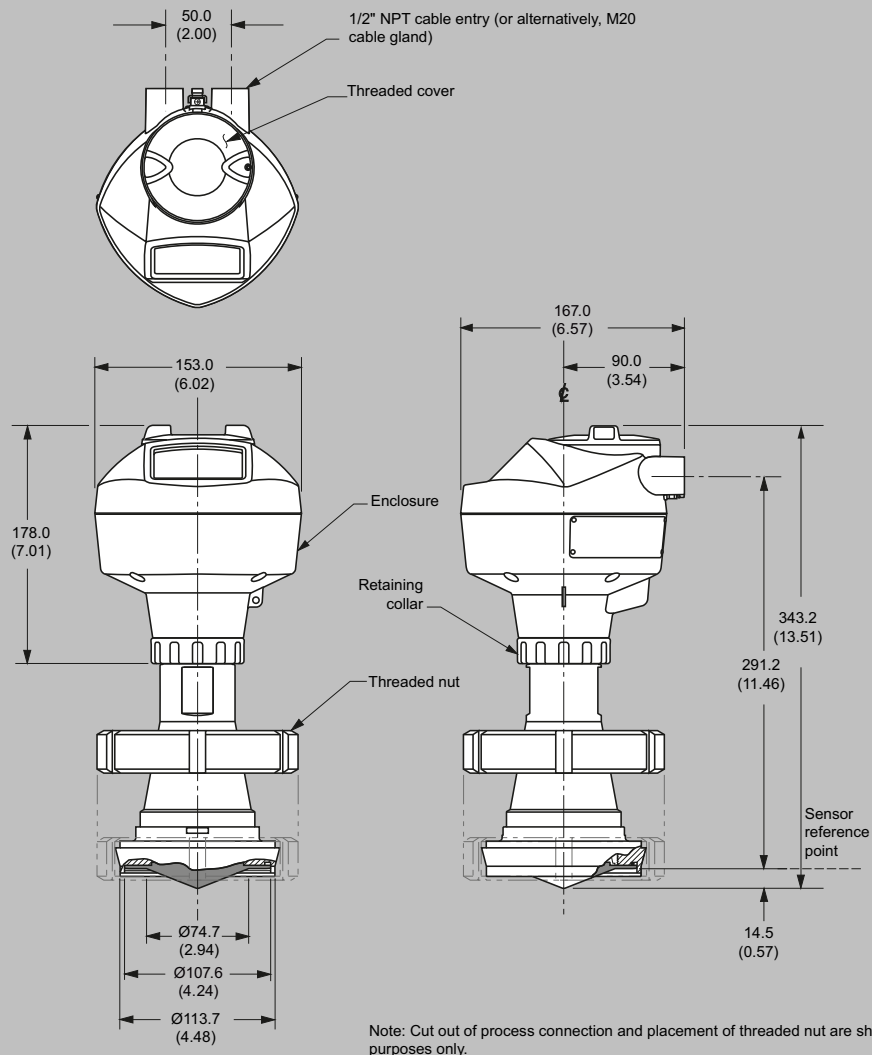

SITRANS LR250 Hygienic Encapsulated Antenna (DN 100 nozzle/slotted nut to DIN 11851), dimensions in mm (inch)

Dimensional drawings (continued)

Hygienic encapsulated antenna (DN 50 aseptic clamp to DIN 11864-1)

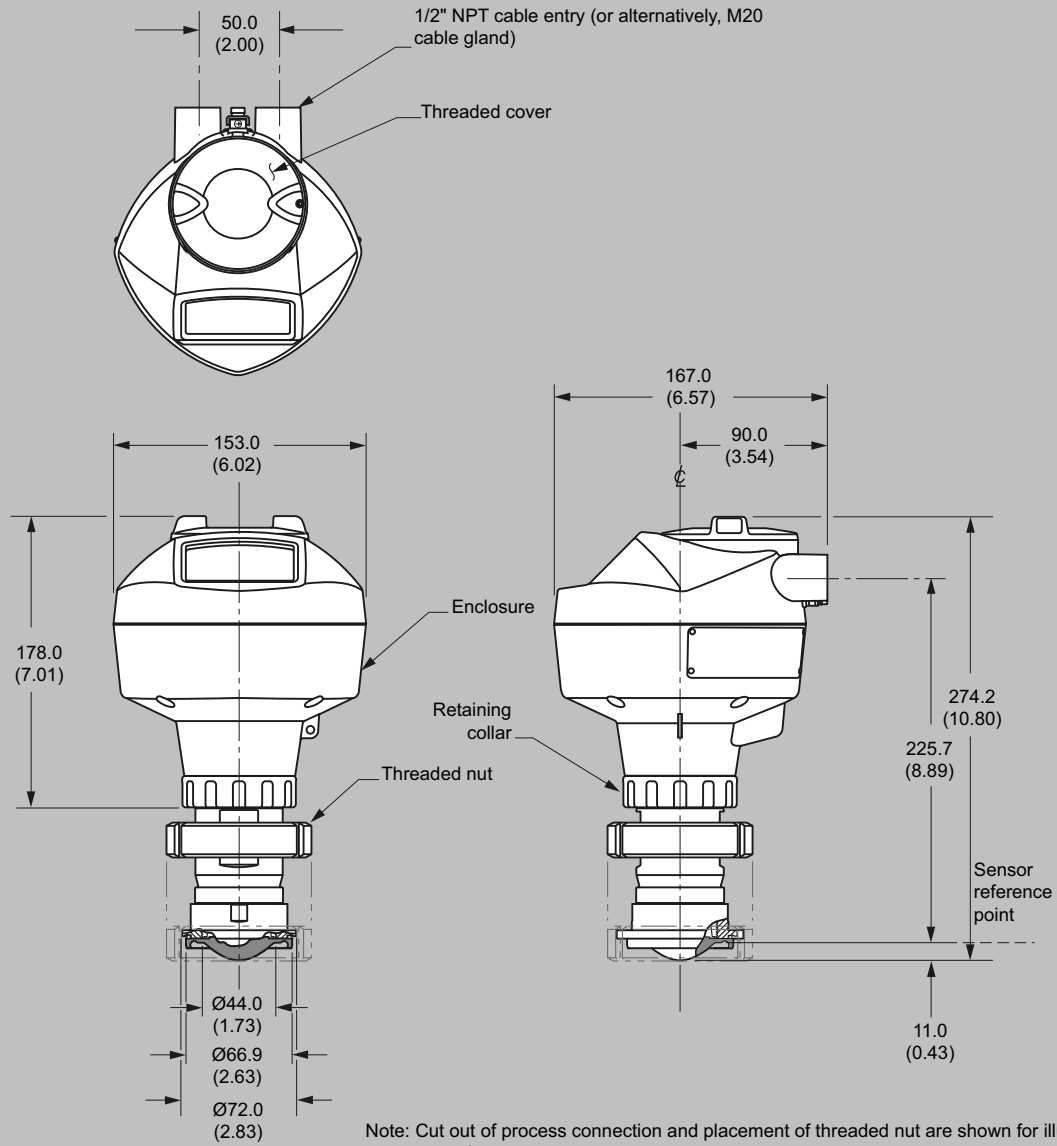

SITRANS LR250 Hygienic Encapsulated Antenna (DN 50 aseptic clamp to DIN 11864-1), dimensions in mm (inch)

SITRANS LR250 Hygienic Encapsulated Antenna

Dimensional drawings (continued)

Hygienic encapsulated antenna (DN 80 aseptic clamp to DIN 11864-1)

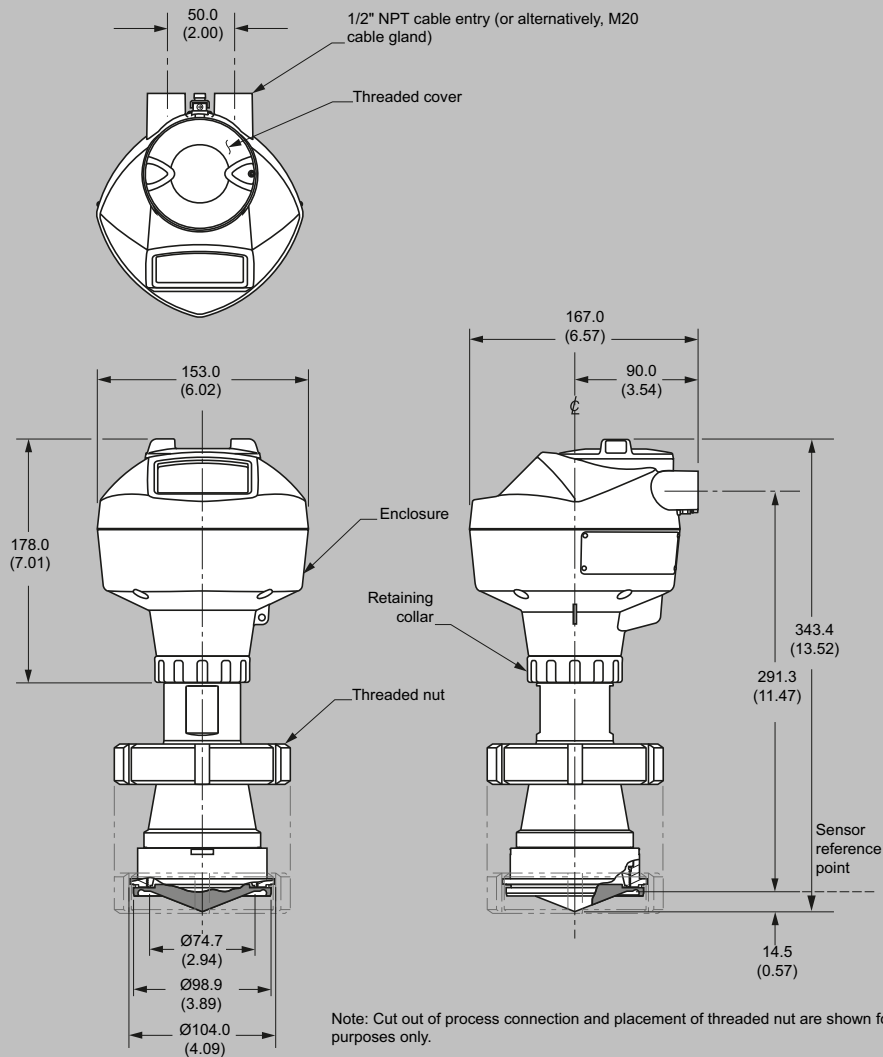

SITRANS LR250 Hygienic Encapsulated Antenna (DN 80 aseptic clamp to DIN 11864-1), dimensions in mm (inch)

Dimensional drawings (continued)

Hygienic encapsulated antenna (DN 100 aseptic clamp to DIN 11864-1)

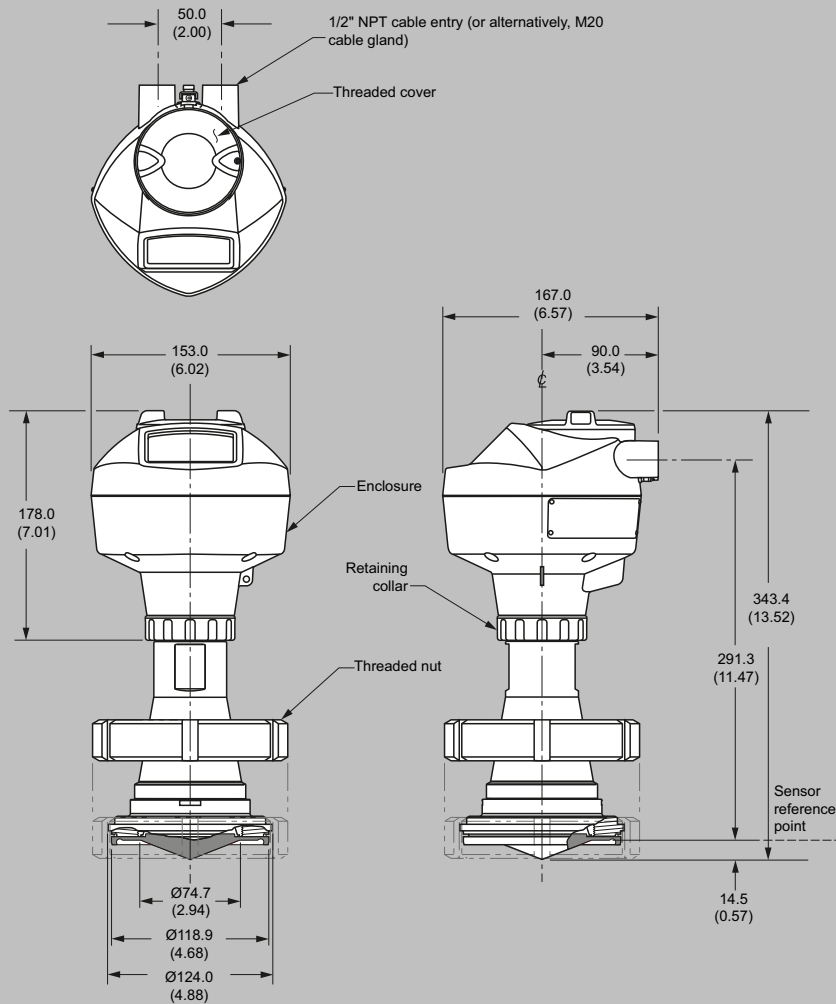

Note: Cut out of process connection and placement of threaded nut are shown for illustration purposes only.

SITRANS LR250 Hygienic Encapsulated Antenna (DN 100 aseptic clamp to DIN 11864-1), dimensions in mm (inch)

SITRANS LR250 Hygienic Encapsulated Antenna

Dimensional drawings (continued)

Hygienic encapsulated antenna (DN 50 aseptic flange to DIN 11864-2)

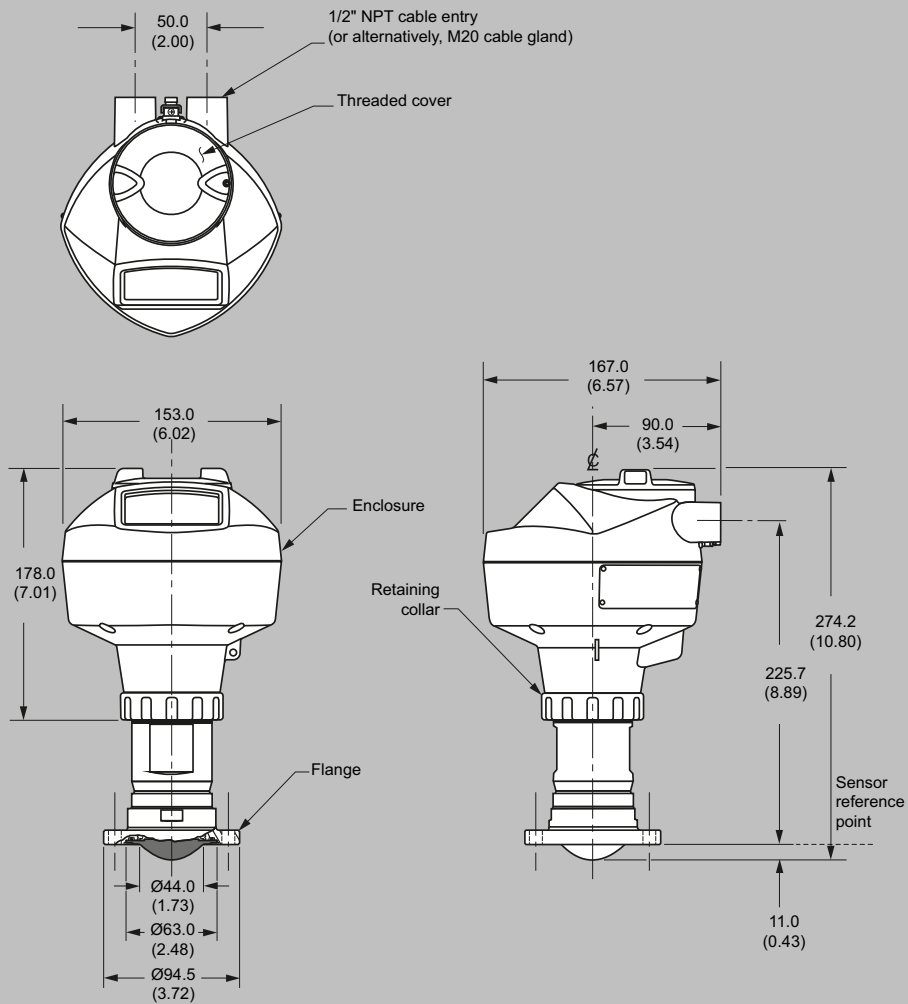

Note: Cut out of process connection and flange are shown for illustration purposes only.

SITRANS LR250 Hygienic Encapsulated Antenna (DN 50 aseptic flange to DIN 11864-2), dimensions in mm (inch)

Dimensional drawings (continued)

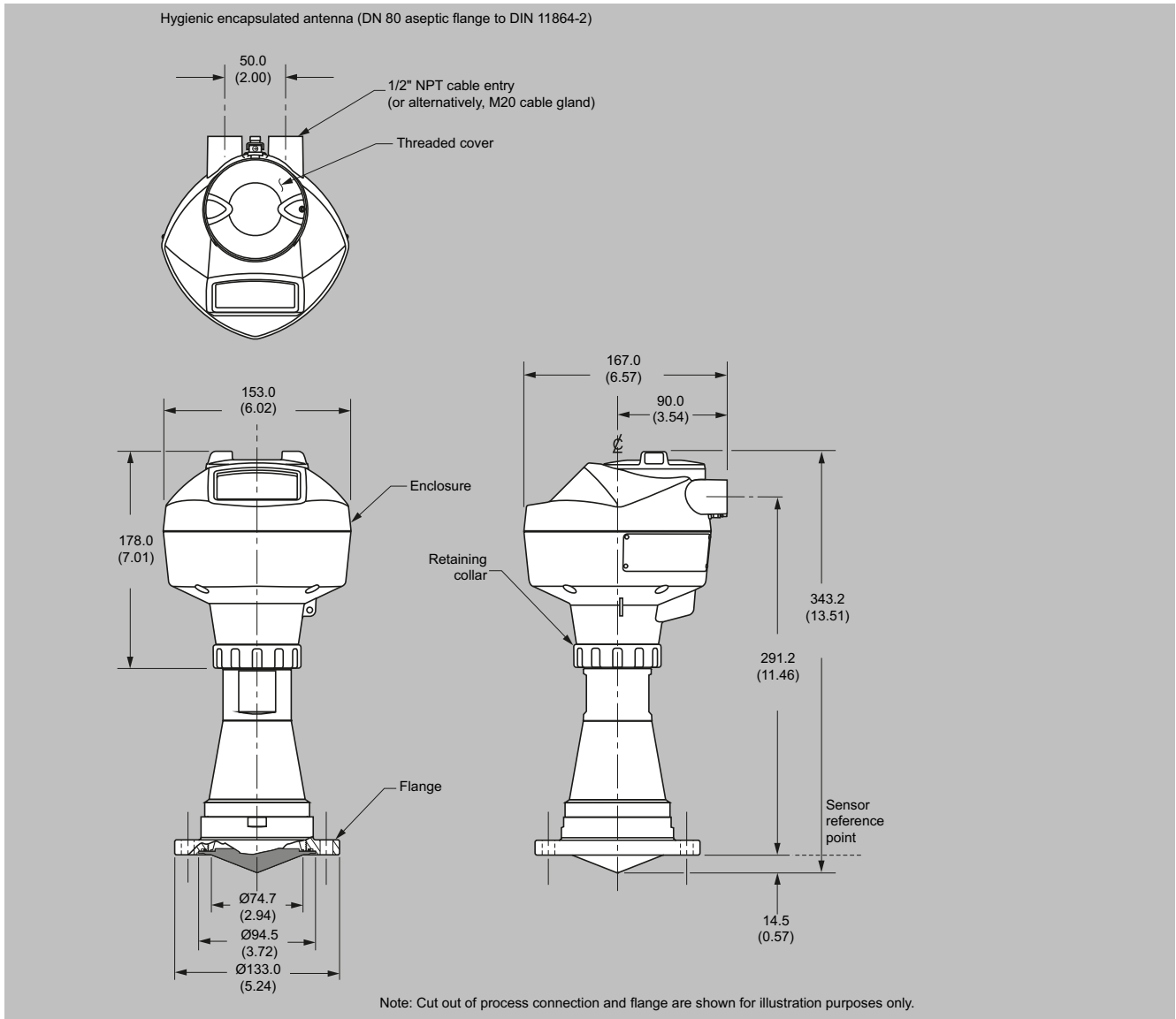

SITRANS LR250 Hygienic Encapsulated Antenna (DN 80 aseptic flange to DIN 11864-2), dimensions in mm (inch)

SITRANS LR250 Hygienic Encapsulated Antenna

Dimensional drawings (continued)

Hygienic encapsulated antenna (DN 100 aseptic flange to DIN 11864-2)

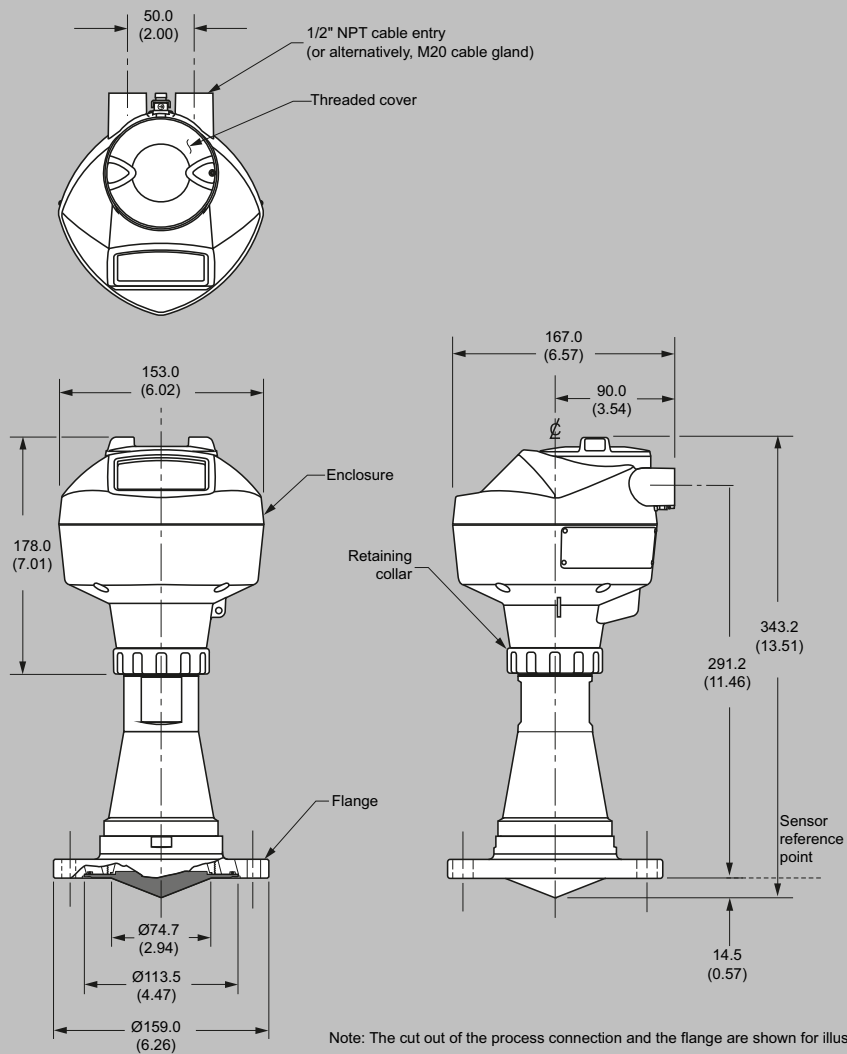

SITRANS LR250 Hygienic Encapsulated Antenna (DN 100 aseptic flange to DIN 11864-2), dimensions in mm (inch)

Dimensional drawings (continued)

Hygienic encapsulated antenna (DN 50 aseptic clamp to DIN 11864-3)

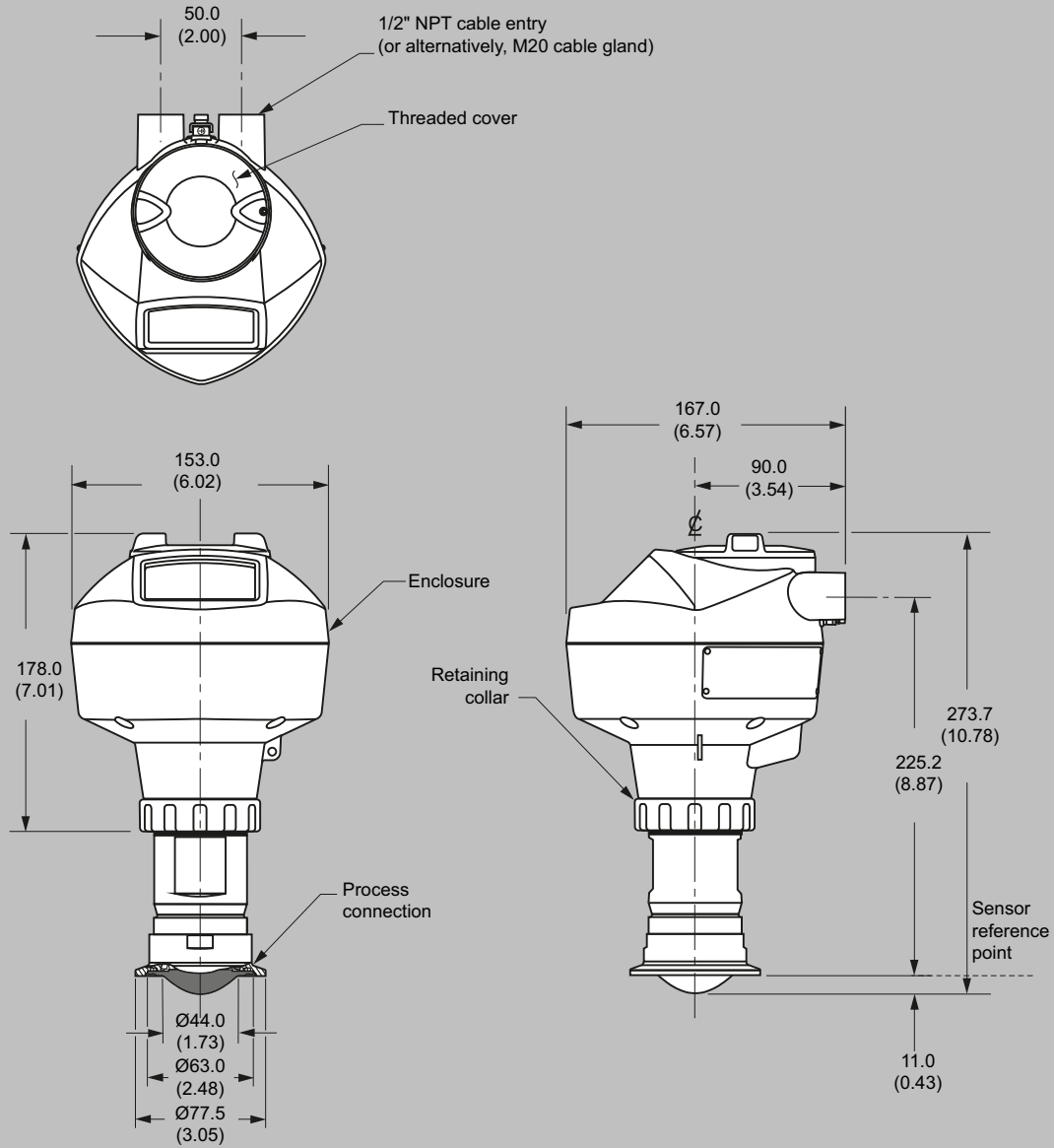

Note: Cut out of process connection is shown for illustration purposes only.

SITRANS LR250 Hygienic Encapsulated Antenna (DN 50 aseptic clamp to DIN 11864-3), dimensions in mm (inch)

SITRANS LR250 Hygienic Encapsulated Antenna

Dimensional drawings (continued)

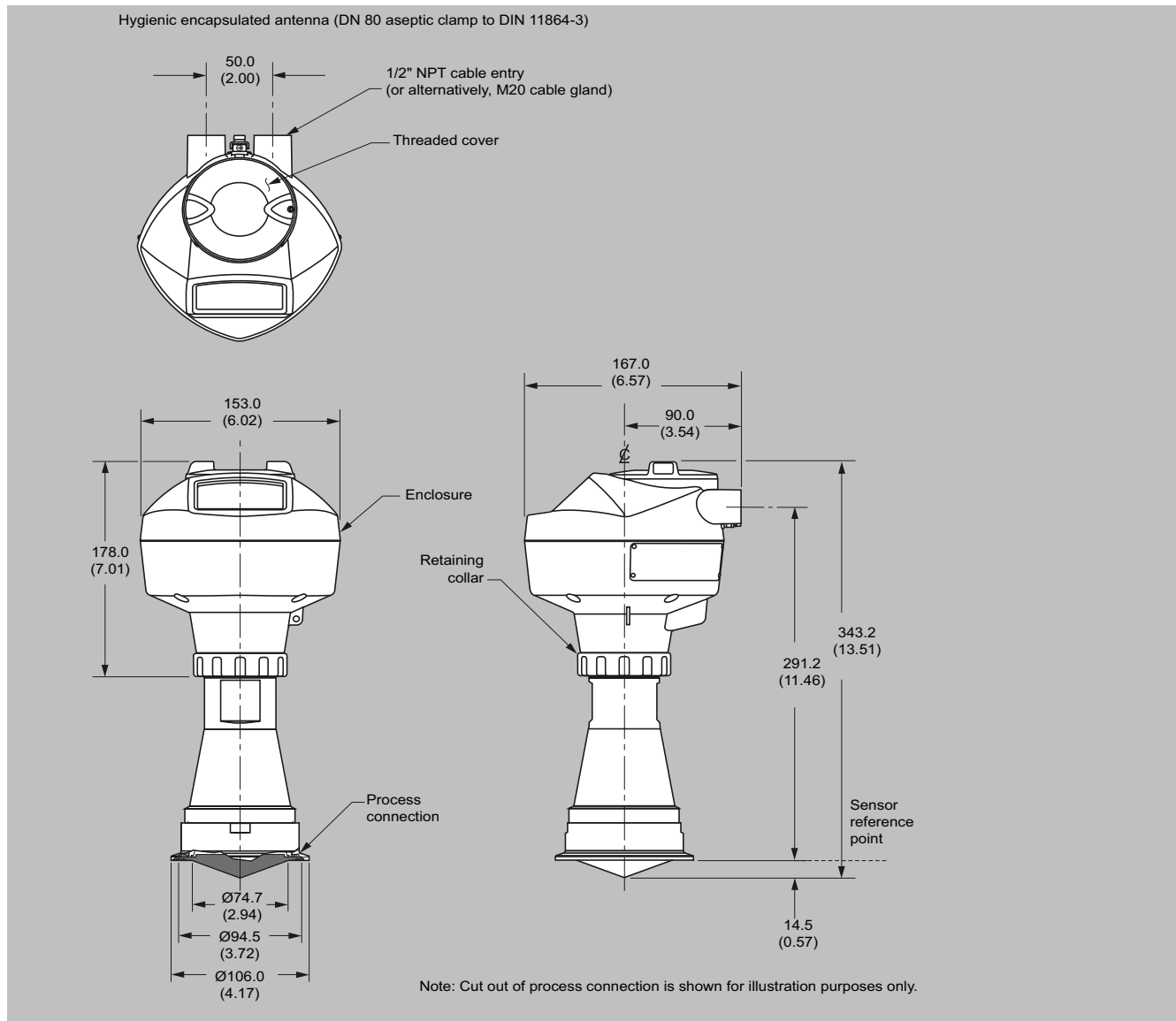

SITRANS LR250 Hygienic Encapsulated Antenna (DN 80 aseptic clamp to DIN 11864-3), dimensions in mm (inch)

Dimensional drawings (continued)

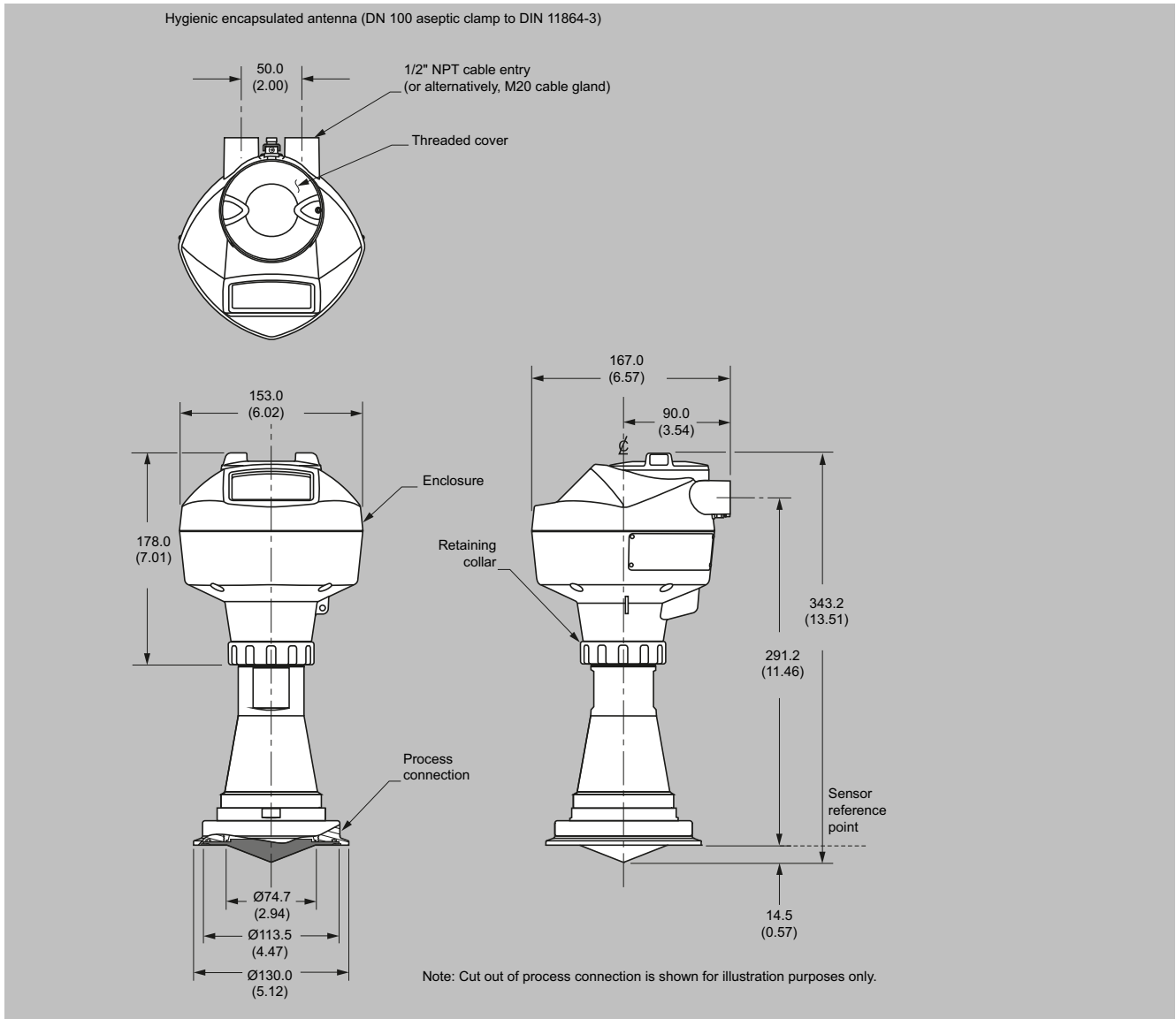

SITRANS LR250 Hygienic Encapsulated Antenna (DN 100 aseptic clamp to DIN 11864-3), dimensions in mm (inch)

SITRANS LR250 Hygienic Encapsulated Antenna

Dimensional drawings (continued)

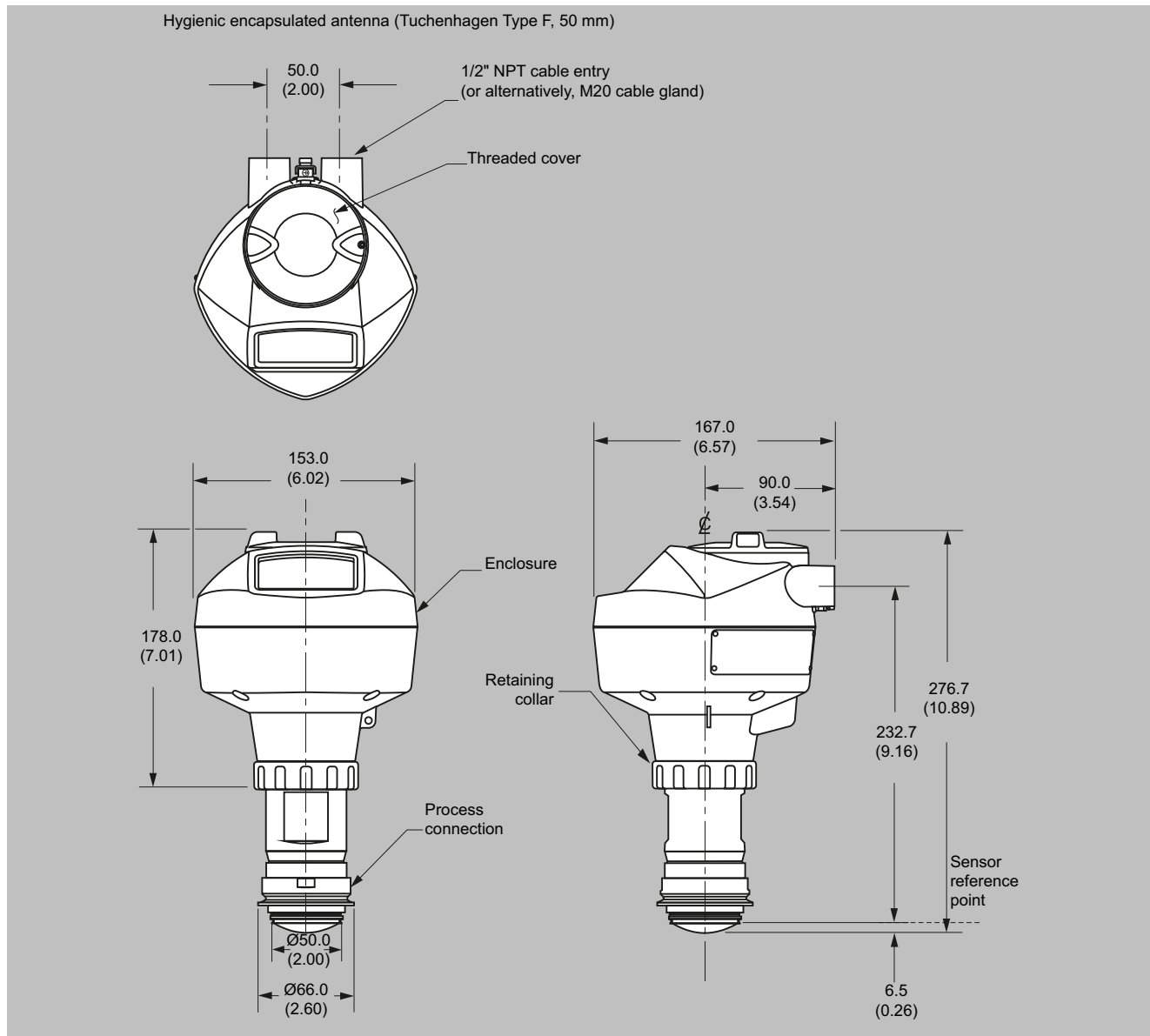

SITRANS LR250 Hygienic Encapsulated Antenna (Tuchenhagen Type F), dimensions in mm (inch)

Dimensional drawings (continued)

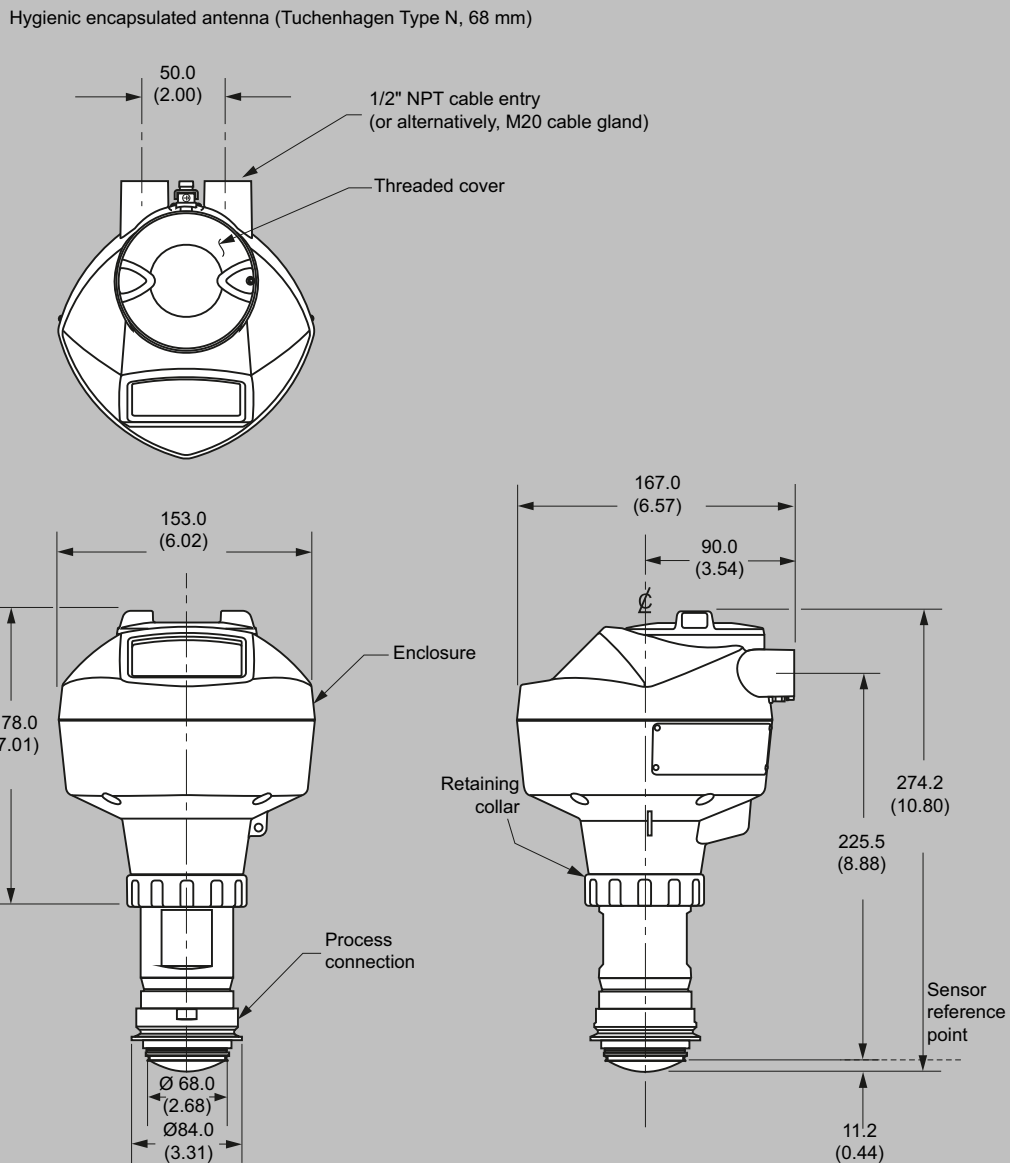

SITRANS LR250 Hygienic Encapsulated Antenna (Tuchenhagen Type N), dimensions in mm (inch)

SITRANS LR250 Hygienic Encapsulated Antenna

Circuit diagrams

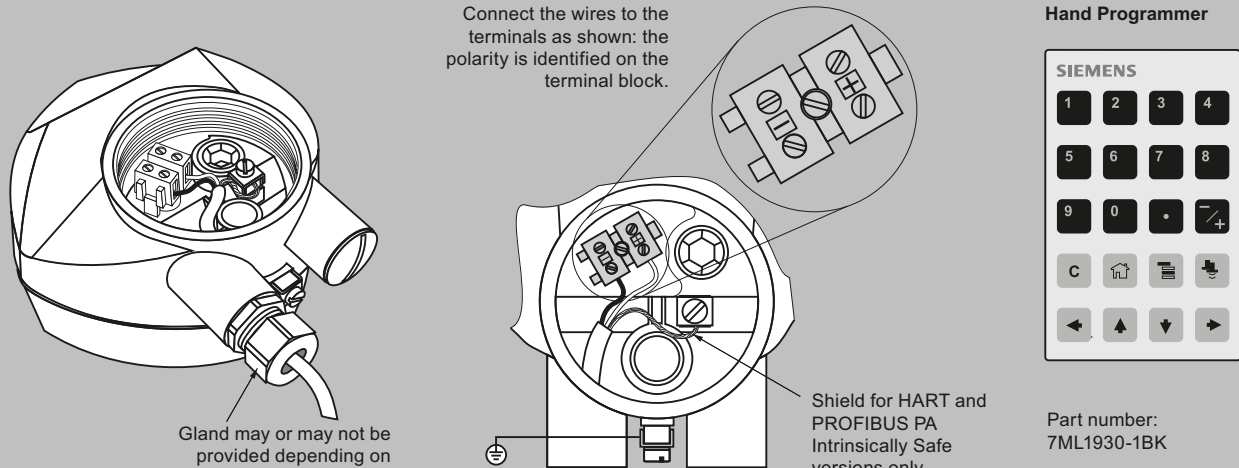

Connect the wires to the terminals as shown: the polarity is identified on the terminal block.

Gland may or may not be provided depending on approval option.

Shield for HART and PROFIBUS PA Intrinsically Safe versions only.

Hand Programmer

SIEMENS			
1	2	3	4
5	6	7	8
9	0	.	/+
C	↑	↓	↔
←	↑	↓	→

Part number:
7ML1930-1BK

Notes:

1. DC terminal shall be supplied from a source providing electrical isolation between the input and output, to meet the applicable safety requirements of IEC 61010-1.
2. All field wiring must have insulation suitable for rated input voltages.
3. Use shielded twisted pair cable (14 ... 22 AWG) for HART version.
4. Separate cables and conduit may be required to conform to standard instrumentation wiring practices or electrical codes.

SITRANS LR250 connections